

BASCO TECHNICAL DATA SHEET

ATM SERIES

MEDICINE CABINET WITH TILTING MIRROR
MODELS

6/30/99

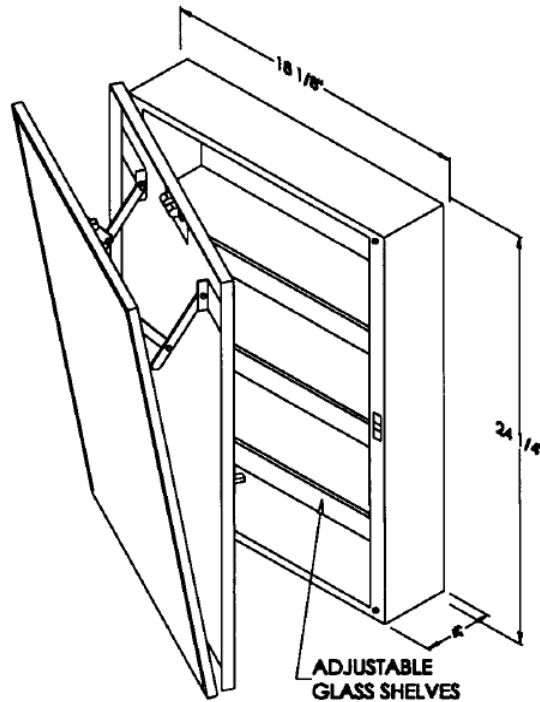

**MODEL SM374P-ATM-W SHOWN
WITH CABINET OPEN AND MIRROR
TILTED**

Recessed	Surface Mounted	Wall Opening (W x H x D)	Overall Size (W x H x D)	Glass Shelves
372P-ATM-W	-	14" X 20" X 3"	16 1/8" X 22 1/8" X 5 3/4"	2
-	SM372P-ATM-W	-	16 1/8" X 22 1/8" X 5 3/4"	2
374P-ATM-W-	-	16" X 22" X 3"	18 1/8" X 24 1/8" X 5 3/4"	3
-	SM374P-ATM-W	-	18 1/8" X 24 1/8" X 5 3/4"	3
375P-ATM-W-	-	14" X 24" X 3"	16 1/8" X 26 1/8" X 5 3/4"	3
-	SM375P-ATM-W	-	16 1/8" X 26 1/8" X 5 3/4"	3

THIS HIGH QUALITY MEDICINE CABINET IS DESIGNED FOR THE USE BY THE HANDICAPPED PERSONS. THE MEDICINE CABINET MIRROR MAY BE USED IN THE UPRIGHT POSITION OR TILTED DOWN TO ACCOMMODATE A SEATED PERSON.

BODY: HEAVY 20 GAUGE PRIME SHEETS OF COLD ROLLED STEEL.

DOOR: HEAVY 20 GAUGE PRIME COLD ROLLED STEEL. DOOR IS EQUIPPED WITH A LATCH TO KEEP THE DOOR CLOSED WHEN MIRROR IS TILTED DOWN. THE TILTED MIRROR IS SECURED BY AN ELBOW HINGE AND A STAINLESS STEEL PIANO HINGE AT THE BOTTOM.

DOOR STOP: STOP HINGE.

FINISH: BONDERIZED AFTER FORMING TO RESIST RUST AND SPRAYED WITH A SPECIAL WHITE ENAMEL, BAKED ON AT HIGH TEMPERATURE FOR DURABILITY.

MIRRORS: 3/16" FIRST QUALITY PLATE GLASS, WITH TWO COATS OF SILVER. THEN ELECTROLYTICALLY COPPER CLAD AS DEFINED IN U.S. COMMERCIAL STANDARD CS-27-36. WARRANTIED FOR 5 YEARS AGAINST SILVERING DEFECTS.

SHELVES: GLASS, ADJUSTABLE 1/4" THICK WITH POLISHED FRONT EDGE.

BASCO TECHNICAL DATA SHEET

ATM SERIES

MEDICINE CABINET WITH TILTING MIRROR
MODELS

6/30/99

MODEL SM374P-ATM-W SHOWN

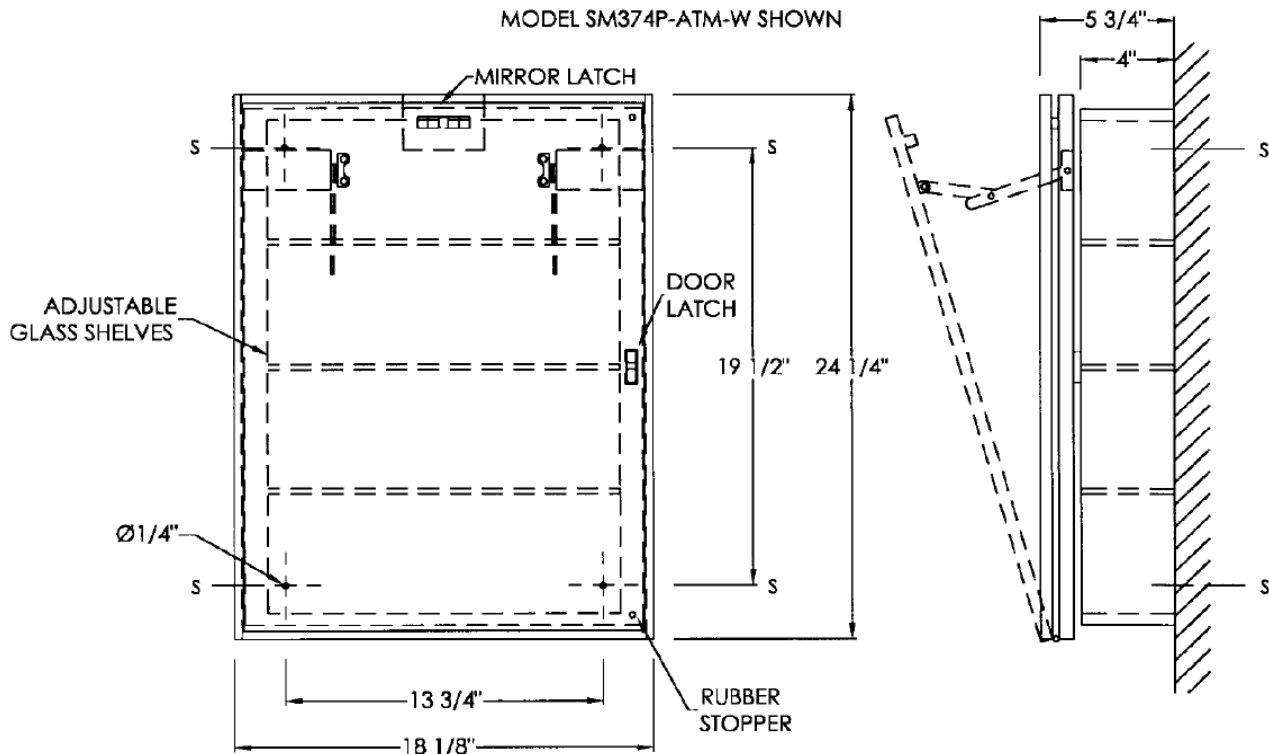

Recessed	Surface Mounted	Wall Opening (W x H x D)	Overall Size (W x H x D)	Glass Shelves
372P-ATM-W	-	14" X 20" X 3"	16 1/8" X 22 1/8" X 5 3/4"	2
-	SM372P-ATM-W	-	16 1/8" X 22 1/8" X 5 3/4"	2
374-ATM-W-	-	16" X 22" X 3"	18 1/8" X 24 1/8" X 5 3/4"	3
-	SM374P-ATM-W	-	18 1/8" X 24 1/8" X 5 3/4"	3
375-ATM-W-	-	14" X 24" X 3"	16 1/8" X 26 1/8" X 5 3/4"	3
-	SM375P-ATM-W	-	16 1/8" X 26 1/8" X 5 3/4"	3

THIS HIGH QUALITY MEDICINE CABINET IS DESIGNED FOR THE USE BY THE HANDICAPPED PERSONS. THE MEDICINE CABINET MIRROR MAY BE USED IN THE UPRIGHT POSITION OR TILTED DOWN TO ACCOMIDATE A SEATED PERSON.

BODY: HEAVY 20 GAUGE PRIME SHEETS OF COLD ROLLED STEEL.

DOOR: HEAVY 20 GAUGE PRIME COLD ROLLED STEEL. DOOR IS EQUIPPED WITH A LATCH TO KEEP THE DOOR CLOSED WHEN MIRROR IS TILTED DOWN. THE TILTED MIRROR IS SECURED BY AN ELBOW HINGE AND A STAINLESS STEEL PIANO HINGE AT THE BOTTOM.

DOOR STOP: STOP HINGE.

FINISH: BONDERIZED AFTER FORMING TO RESIST RUST AND SPRAYED WITH A SPECIAL WHITE ENAMEL, BAKED ON AT HIGH TEMPERATURE FOR DURABILITY.

MIRRORS: 3/16" FIRST QUALITY PLATE GLASS, WITH TWO COATS OF SILVER. THEN ELECTROLYTICALLY COPPER CLAD AS DEFINED IN U.S. COMMERCIAL STANDARD CS-27-36. WARRANTIED FOR 5 YEARS AGAINST SILVERING DEFECTS.

SHELVES: GLASS, ADJUSTABLE 1/4" THICK WITH POLISHED FRONT EDGE.