

BASCO TECHNICAL DATA SHEET

HTM SERIES

6/29/99

FIXED TILTING MIRROR MODELS

MODEL HTM-36X30-W SHOWN

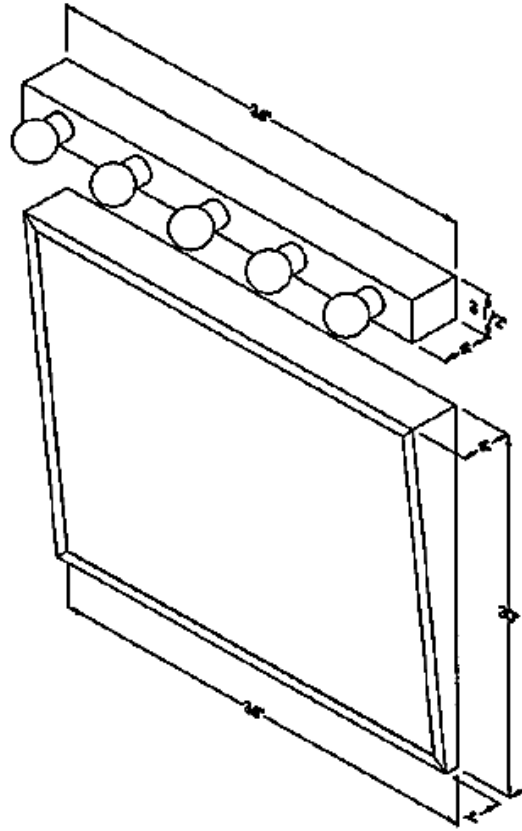

Mirror Model Numbers	Overall Size (W x H)	Matching Light Models	Overall Size (W x H x D)	Number of Bulbs
HTM-16X30-W	16" X 30"	L4W-16	16" X 3-1/2" X 4"	3
HTM-18X24-W	18" X 24"	L4W-18	18" X 3-1/2" X 4"	3
HTM-18X30-W	18" X 30"	L4W-18	18" X 3-1/2" X 4"	3
HTM-24X30-W	24" X 30"	L4W-24	24" X 3-1/2" X 4"	4
HTM-30X24-W	30" X 24"	L4W-30	30" X 3-1/2" X 4"	5
HTM-36X30-W	36" X 30"	L4W-36	36" X 3-1/2" X 4"	5
HTM-48X24-W	48" X 24"	L4W-48	48" X 3-1/2" X 4"	6
HTM-48X30-W	48" X 30"	L4W-48	48" X 3-1/2" X 4"	6

THIS FIXED TILTING MIRROR TAKES THE INSTITUTIONAL LOOK OUT OF ACCESSORIES FOR THE HANDICAPPED.

MIRRO FRAME: HEAVY 20 GAUGE PRIME SHEETS OF COLD ROLLED STEEL. BONDERIZED AFTER FORMING TO RESIST RUST AND PAINTED WITH A SPECIAL WHITE ENAMEL, BAKED ON AT HIGH TEMPERATURE FOR DURABILITY.

MIRROR: 3/16" FIRST QUALITY PLATE GLASS, WITH TWO COATS OF SILVER. THEN ELECTROLYTICALLY COPPER CLAD AS DEFINED IN U.S. COMMERCIAL STANDARD CS-27-36. WARRANTIED FOR 5 YEARS AGAINST SILVERING DEFECTS. MIRROR IS REINFORCED WITH A SHOCK ABSORBING FILLER AND A 20 GAUGE STEEL BACK PLATE. MIRRORS PROJECT 4" FROM THE WALL AT TOP AND 1" AT THE BOTTOM.

MIRRORS ARE MOUNTED ON A CONCEALED WALL HANGER FABRICATED OF 20 GAUGE GAVANIZED STEEL.

L4W LIGHT SERIES: BASCO'S L4W SERIES LIGHT FIXTURES ARE ESPECIALLY MADE 4" DEEP TO COMPLEMENT THE TILTING MIRRORS AND ARE ALSO PAINTED WHITE ENAMEL TO MATCH THE MIRROR.

BASCO TECHNICAL DATA SHEET

HTM SERIES

6/29/99

FIXED TILTING MIRROR MODELS

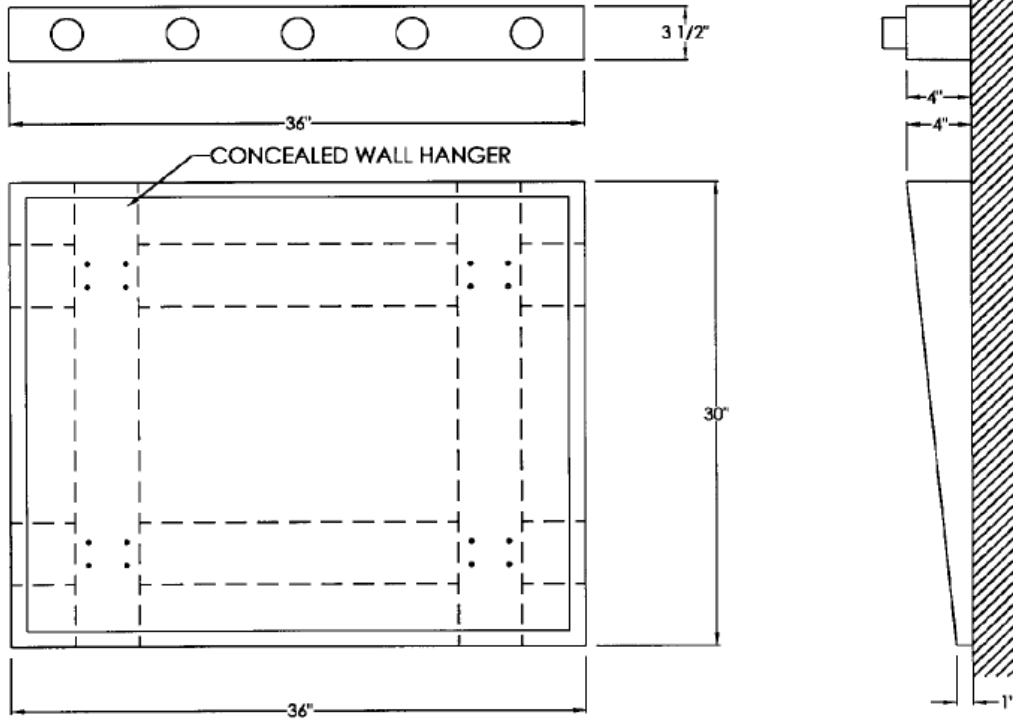

Mirror Model Numbers	Overall Size (W x H)	Matching Light Models	Overall Size (W x H x D)	Number of Bulbs
HTM-16X30-W	16" X 30"	L4W-16	16" X 3-1/2" X 4"	3
HTM-18X24-W	18" X 24"	L4W-18	18" X 3-1/2" X 4"	3
HTM-18X30-W	18" X 30"	L4W-18	18" X 3-1/2" X 4"	3
HTM-24X30-W	24" X 30"	L4W-24	24" X 3-1/2" X 4"	4
HTM-30X24-W	30" X 24"	L4W-30	30" X 3-1/2" X 4"	5
HTM-36X30-W	36" X 30"	L4W-36	36" X 3-1/2" X 4"	5
HTM-48X24-W	48" X 24"	L4W-48	48" X 3-1/2" X 4"	6
HTM-48X30-W	48" X 30"	L4W-48	48" X 3-1/2" X 4"	6

THIS FIXED TILTING MIRROR TAKES THE INSTITUTIONAL LOOK OUT OF ACCESSORIES FOR THE HANDICAPPED.

MIRRO FRAME: HEAVY 20 GAUGE PRIME SHEETS OF COLD ROLLED STEEL. BONDERIZED AFTER FORMING TO RESIST RUST AND PAINTED WITH A SPECIAL WHITE ENAMEL, BAKED ON AT HIGH TEMPERATURE FOR DURABILITY.

MIRROR: 3/16" FIRST QUALITY PLATE GLASS, WITH TWO COATS OF SILVER. THEN ELECTROLYTICALLY COPPER CLAD AS DEFINED IN U.S. COMMERCIAL STANDARD CS-27-36. WARRANTIED FOR 5 YEARS AGAINST SILVERING DEFECTS. MIRROR IS REINFORCED WITH A SHOCK ABSORBING FILLER AND A 20 GAUGE STEEL BACK PLATE. MIRRORS PROJECT 4" FROM THE WALL AT TOP AND 1" AT THE BOTTOM.

MIRRORS ARE MOUNTED ON A CONCEALED WALL HANGER FABRICATED OF 20 GAUGE GAVANIZED STEEL.

L4W LIGHT SERIES: BASCO'S L4W SERIES LIGHT FIXTURES ARE ESPECIALLY MADE 4" DEEP TO COMPLEMENT THE TILTING MIRRORS AND ARE ALSO PAINTED WHITE ENAMEL TO MATCH THE MIRROR.